

---

# Prophylaxis for Hereditary Angioedema with Lanadelumab and C1 Inhibitors: Effectiveness and Value

Public Meeting – October 25, 2018



INSTITUTE FOR CLINICAL  
AND ECONOMIC REVIEW

Wi-Fi: TCEGUEST

---

# Welcome and Introduction

- California Technology Assessment Forum (CTAF)
- The Institute for Clinical and Economic Review (ICER)

# Sources of Funding, 2018

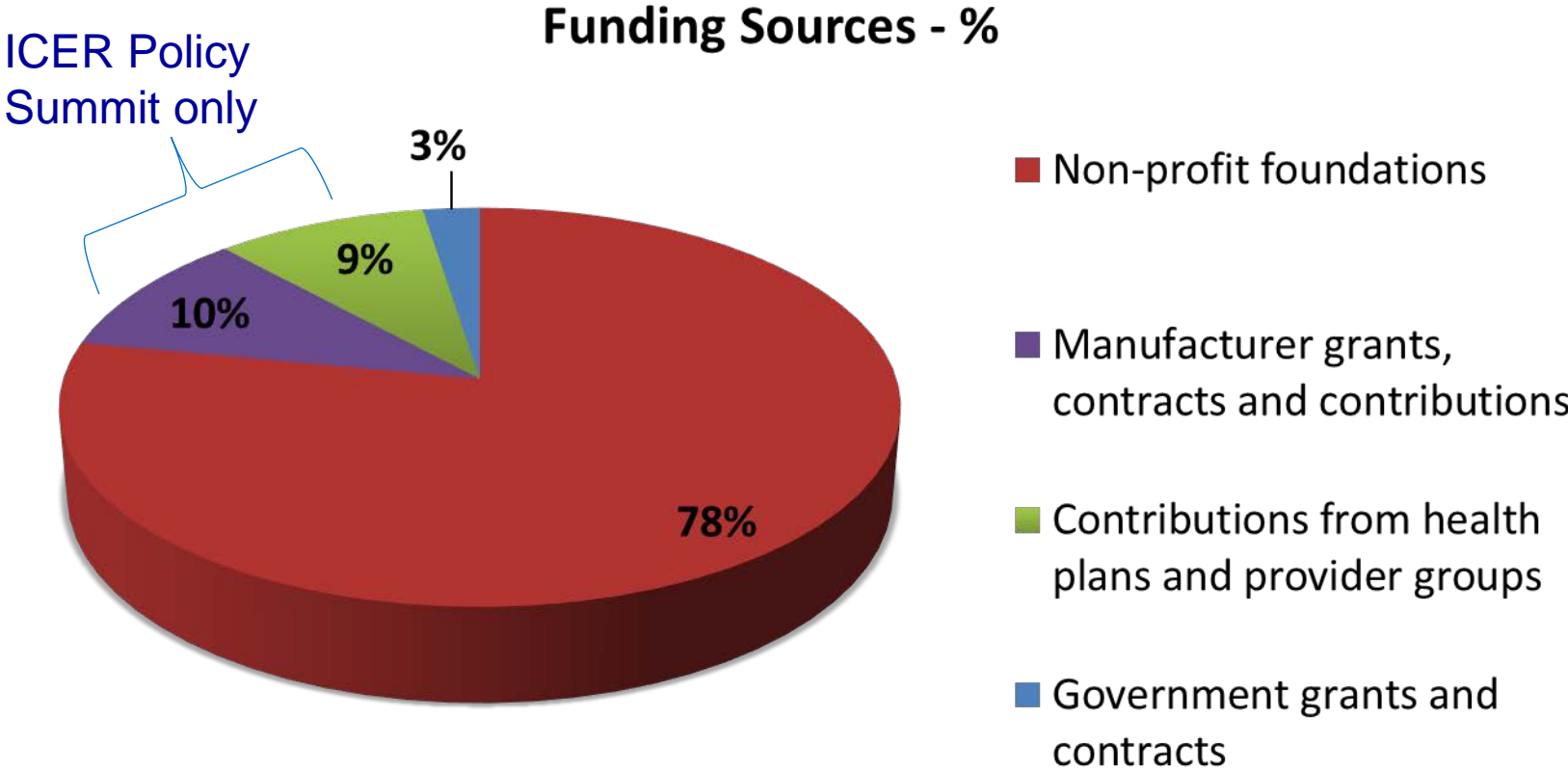

---

# Welcome and Introduction

- **Why are we here today?**
  - New treatment paradigm, innovation promising substantial benefits to patients and their families

The swelling attacks come on without warning. Loukisha Olive-McCoy's lower lip puffs up; then her cheeks and jaw twist and pull, distorting her face into an involuntary grimace. Sometimes her tongue will fill up the back of her throat and choke off her breathing...

"I'm very expensive," Olive-McCoy said. "By the end of the year, our pharmaceutical bill, meds alone, can be \$1 million, can be \$2 million — without even trying."

*-- From "Mother, wife, million-dollar patient,"  
Washington Post, April 25, 2018*

---

# Welcome and Introduction

- **Why are we here today?**
  - New mechanisms of action often raise questions about appropriate use, cost
  - Patients can have difficulty accessing drugs
    - Prior authorization criteria
    - Requirements to switch drugs with new insurance
    - High out-of-pocket costs
  - Benefit of independent evaluation and public discussion of the evidence on effectiveness and value

---

# Welcome and Introduction

## How was the ICER report on prophylactic treatments for hereditary angioedema developed?

- Scoping with guidance from patients, clinical experts, manufacturers, and other stakeholders
- UCSF/ICER evidence analysis
- University of Washington cost-effectiveness modeling
- Public comment and revision
- Expert report reviewers
  - Marco Cicardi, MD
  - Stephanie Smith, HAE Patient
- How is the evidence report structured to support CEPAC voting and policy discussion?

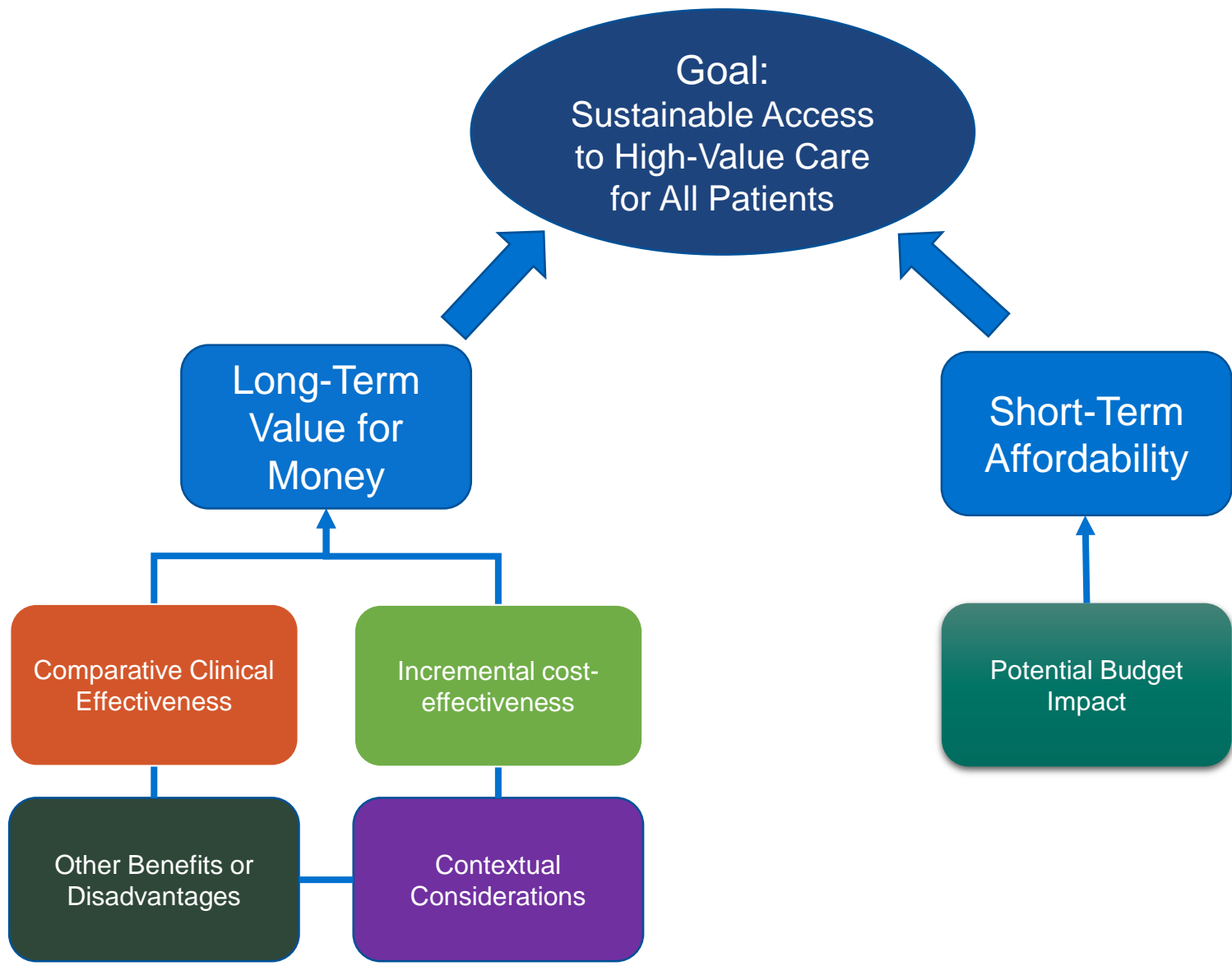

---

# Agenda

- 10:00 am:** Welcome and Opening Remarks
- 10:15 am:** Presentation of the Evidence  
**Evidence Review:** Grace Lin, MD, MAS, UCSF  
**Cost Effectiveness:** Solomon Lubinga, PhD, MSc, UW
- 11:15 am:** Public Comment and Discussion
- 11:25 am:** Manufacturer Public Comment and Discussion
- 11:35 am:** Lunch
- 12:20 pm:** CTAF Deliberation and Votes
- 1:20 pm:** Break
- 1:35 pm:** Policy Roundtable
- 2:35 pm:** Reflections
- 3:00 pm:** Meeting Adjourned



---

# Clinical and Patient Experts

- **Marco Cicardi, MD**, Professor of Medicine, Università degli Studi di Milano, Italy
  - Disclosures
    - Consulting fees >\$5,000: CSL Behring, Shire
    - Speaker's bureau: CSL Behring, Pharming, Shire
    - Research, educational support: Pharming, Shire
    - Primary investigator in trials of: Haegarda, lanadelumab
- **Stephanie Smith**
  - Disclosures
    - Honoraria >\$5,000 from CSL Behring for patient advocacy

---

# Evidence Review

**Grace A. Lin, MD, MAS**

Associate Professor of Medicine

University of California San Francisco



INSTITUTE FOR CLINICAL  
AND ECONOMIC REVIEW

---

*Key review team members:*

**Foluso Agboola, MBBS, MPH, Director,  
Evidence Synthesis, ICER**

*Disclosures:*

We have no conflicts of interest relevant to this report.

# Topic in Context

- HAE is a rare genetic disease characterized by painful, recurrent swelling in various parts of the body
- $\downarrow$  C1-inhibitor  $\longrightarrow$   $\uparrow$  bradykinin  $\longrightarrow$  tissue swelling
- Estimated prevalence ~1:50,000 (~6500 in US)
- Attacks are disfiguring and, rarely, fatal

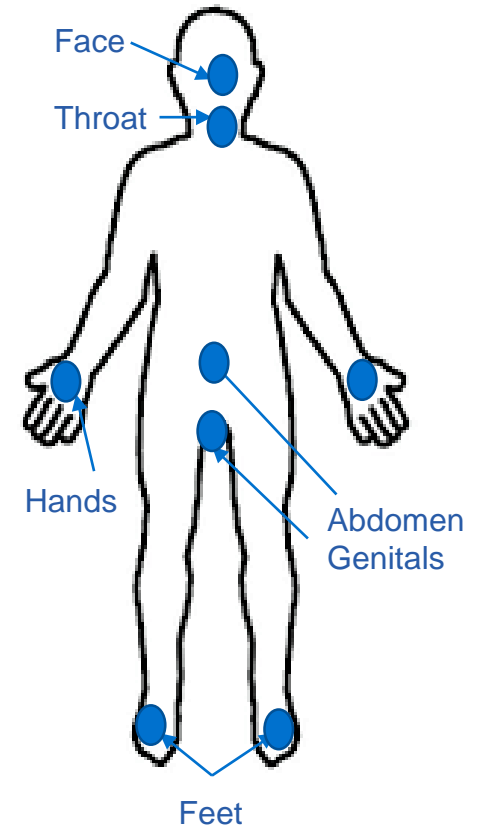

# Effect on Lives Can Be Profound



WITHOUT



DURING



Abdominal swelling during an HAE attack



*All images from US Hereditary Angioedema Association website ([www.haea.org](http://www.haea.org))*

---

# Types of HAE

There are three types of HAE:

## Type 1

- Most common type
- Deficiency in C1-inhibitor (C1-INH)

## Type 2

- Less common
- Dysfunction of C1-INH

## Type 3

- Prevalence uncertain
- Normal levels and function of C1-INH

---

# Effect on Lives Can Be Profound

- HAE attacks:
  - Variable rate, can be triggered or spontaneous
  - Last 2-5 days untreated
- Often delay of years before diagnosis made, resulting in inappropriate treatments (e.g., surgery for abdominal attacks)
- Unpredictability of attacks results in:
  - Anxiety and depression
  - Limitations in patient's ability to work, go to school, and participate in leisure activities
  - Significant caregiver burden

---

# Management of HAE

- Guidelines suggest treatment for three situations:
  - **On-demand therapy:** All acute attacks may be treated to decrease severity and duration
  - **Short-term prophylaxis:** Situations that might trigger an attack
  - **Long-term prophylaxis:** Patients with high disease burden or significant decrease in quality of life
- Main treatments are C1-inhibitor replacement or drugs targeting the kallikrein pathway



---

# Long-Term Prophylaxis

- Goal to prevent or reduce frequency and severity of HAE attacks
- Individualized decision – factors affecting decision to start long-term prophylaxis:
  - Frequency, severity of attacks
  - Impact on quality of life
  - Access to on-demand therapy and medical care
  - Patient preference

---

# Scope of the Review

- Long-term prophylactic treatment for HAE 1/2
  - Drugs: C1-INHs and lanadelumab
  - Population: patients with HAE 1/2
  - Comparator: no long-term prophylaxis, treatment with on-demand therapy only
  - Key outcome: reduction in HAE attacks
  - Secondary outcomes: severity of attacks, use of rescue medication, quality of life, patient-reported outcomes, depression or anxiety, mortality

# Treatments for Long-Term Prophylaxis for HAE

Drug (Brand Name)	Manufacturer	FDA Approval	Mechanism of Action	Method of Delivery	Approved Population
Plasma-Derived C1-INH (Cinryze)	Shire Plc	2008	C1-INH replacement	Intravenous infusion 3-4x weekly	Ages 6 and older
Plasma-Derived C1-INH (Haegarda)	CSL Behring GmbH	2017	C1-INH replacement	Subcutaneous injection 3-4x weekly	Ages 12 and older
Lanadelumab (Takhzyro)	Shire Plc	2018	Kallikrein inhibitor	Subcutaneous injection every 2-4 weeks	Ages 12 and older

---

# Insights from Discussions with Patients

- Impact of HAE attacks
  - Debilitating, could be life-threatening (laryngeal attacks)
  - Cause missed days of school or work
  - Unpredictable attacks cause anxiety and depression, alteration of activities due to fear of attacks
  - Caregiver burden
- Other concerns
  - Concern about passing condition to children
  - Worry about access to medication and out-of-pocket costs
- Subcutaneous therapy preferred over intravenous therapy for convenience

# Issues of Focus

# Key Clinical Trials

	Cinryze (Zuraw 2010)	Haegarda (COMPACT)	Lanadelumab (HELP)
Eligibility Criteria	Age ≥ 6 years ≥ 2 attacks/month	Age ≥ 12 years ≥ 2 attacks/ month requiring immediate medical attention	Age ≥ 12 years ≥ 1 attack/month
Study Design	Phase III, cross-over, RCT	Phase III, cross-over, RCT	Phase III, parallel-arm, RCT
Outcome Measurement	Patient-reported HAE attacks	Investigator-confirmed HAE attacks	Investigator-confirmed HAE attacks
Study Population	N = 22 Mean age: 34.5 Female: 86%	N = 90 Mean age: 39.6 Female: 67%	N = 125 Mean age: 41 Female: 64%
	Baseline attack/month: NR	Baseline attack/month: 3.3	Baseline attack/month: 3.5
Treatment Duration	12 weeks	16 weeks	26 weeks

***Due to differences between trials (study population, outcomes, treatment duration), no NMA done***

---

## Cinryze *(intravenous plasma-derived C1-INH)*

- Key trial: Phase III, crossover RCT comparing Cinryze 1,000 IU every 3-4 days vs. placebo (Zuraw 2010)
- 50.5% reduction in HAE attacks/month vs. placebo (2.09 vs 4.24), 18.2% attack-free
- Also had significant decrease in:
  - Severity of attacks (1.2 vs 1.9, with 1=mild, 3=severe)
  - Duration of attacks (2.1 vs 3.4 days)
  - Need for rescue therapy (4.7 vs 15.4 doses of on-demand therapy)
- RCT in pediatric population (ages 6-12) also showed efficacy in reducing attack frequency and severity
- Single arm open label extension trial also showed continued efficacy of Cinryze

---

## Haegarda (*subcutaneous plasma-derived C1-INH*)

- Key trial (COMPACT): Phase III, crossover RCT comparing Haegarda 40 IU/kg or 60 IU/kg every 3-4 days vs. placebo
- Both doses were effective in reducing attacks vs. placebo
  - 84% decrease in attacks for 60 IU/kg dose (0.5 vs 4.0 attacks/month), 40% attack-free
- Also decreased vs. placebo:
  - Mean severity of attack (1.6 vs 1.9, 1=mild, 3=severe)
  - Number of days of HAE attack/month (1.6 vs 7.5 days)
  - Number of rescue therapy/month (0.3 vs 3.9)
- Package label dosage is 60 IU/kg every 3-4 days



---

# Lanadelumab

- Key trial (HELP): Phase III RCT comparing lanadelumab (300 mg q2 weeks, 300 mg q4 weeks, 150 mg q4 weeks) vs. placebo
- 73-87% decrease in total HAE attacks
  - 300 mg q2 week dosage most effective, 44% attack-free
- Similar decreases in both attacks requiring on-demand therapy and moderate and severe attacks vs. placebo
  - Best outcomes with 300 mg q2 week dosage
- Package label states to start with 300 mg subcutaneously every 2 weeks, then if attack free for 6 months, consider switching to 300 mg subcutaneously every 4 weeks

# Summary of Clinical Efficacy

	Mean HAE Attacks/Month (Prophylaxis vs. Placebo)	Percentage Reduction in Total HAE Attack Compared to Placebo	Proportion of Patients Attack-Free vs. Placebo
<b>Cinryze vs. Placebo – Zuraw 2010</b>			
Cinryze 1,000 IU	2.1 vs. 4.2	50.5%	18.2%
<b>Haegarda vs. Placebo – COMPACT Trial</b>			
Haegarda 60 IU/kg	0.5 vs. 4.0	84.0%	40.0%
<b>Lanadelumab vs. Placebo – HELP Trial</b>			
Lanadelumab 300 mg q4weeks	0.5 vs. 2.0	73.0%	31.4%
Lanadelumab 300 mg q2weeks	0.3 vs. 2.0	87.0%	44.4%

---

# Patient-Reported Outcomes

- Cinryze
  - Increase in physical and mental health components of SF-36 in adult patients
- Haegarda
  - Improvement in work presenteeism, less productivity and activity loss on Work Productivity and Activity Impairment (WPAI) questionnaire
  - No difference in quality of life based on EQ-5D or Hospital Anxiety and Depression Scale (HADS)
- Lanadelumab
  - Improvement in Angioedema Quality of Life scale

---

# Harms

- No serious adverse events in recorded in any trial
- No differences from placebo in discontinuation due to adverse events in any trial
- Mild to moderate adverse events:
  - Thromboembolic events with Cinryze
  - Injection site reactions with subcutaneous drugs (Haegarda and lanadelumab)
  - Dizziness, headache, hypersensitivity reactions, mild infections
- Theoretical risk of virus transmission with human plasma-derived products (Cinryze, Haegarda)

---

## Potential Other Benefits and Contextual Considerations

- Subcutaneous administration (Haegarda and lanadelumab):
  - Reduces complexity and burden of administration
  - Reduces risk of long-term complications of repeated intravenous infusions
- Lanadelumab offers a novel mechanism of action for patients not optimally controlled on C1-INH therapy

---

## Controversies and Uncertainties

- Evidence base is limited to small RCTs vs placebo, no head-to-head trials
- Lack of data on durability of treatment response and long-term safety due to short duration of trials
- Limited data in children, pregnant/lactating women
- Limited data on quality of life, other patient-reported outcomes
- No clear guidelines on when to start long-term prophylaxis

---

# Public Comments Received

- Ruconest no longer under consideration by FDA for long-term prophylaxis
  - Removed from clinical effectiveness review
  - Removed from cost-effectiveness and budget impact analyses other than use as on-demand therapy

---

# ICER Evidence Ratings for Drugs for Long-Term Prophylaxis of HAE 1/2

- High certainty of net benefit for C1-INHs vs. prophylaxis for long-term prophylaxis of HAE 1/2 (A)
  - Long-term safety data available for Cinryze and from use of C1-INHs for on-demand therapy
- Promising but inconclusive benefit for lanadelumab due to long-term safety concerns (P/I)
  - No data on durability or long-term safety
- There is insufficient evidence (I) for the three drugs compared to each other
  - No head-to-head trials
  - Due to difference in trial characteristics, NMA was not done



**Questions**

---

# Cost Effectiveness

**Solomon Lubinga, PhD, MSc**

Senior Fellow, Department of Pharmacy

University of Washington



INSTITUTE FOR CLINICAL  
AND ECONOMIC REVIEW

---

# Contributors

**Josh Carlson, PhD, MPH**, Associate Professor, UW

**Rick Chapman, PhD, MS**, Director of Health Economics,  
ICER

## *Disclosures*

We have no conflicts of interests relevant to this report.

---

# Objective

- To estimate the cost-effectiveness of lanadelumab and C1 inhibitors (Cinryze and Haegarda) for long-term prophylaxis against acute attacks in patients with HAE 1/2

# Inputs and Assumptions

---

# Methods

- Cycle time: 1 month
- Time horizon: Lifetime
- Population:
  - Age: 39.6 years old; Sex: 68.4% female
  - Weight: female 76.4 kg, male 88.8 kg (average US adults)
  - Attack frequency: 3.39 attacks per month
- Interventions: Cinryze, Haegarda, and lanadelumab
- Comparator: No long-term prophylaxis
- Outcomes: \$/QALY gained and \$/attack avoided
- Perspective: Base case - US health care system  
Scenario - Societal
- Costs: 2018 US dollars

---

# Model Structure: Two-State Markov Model

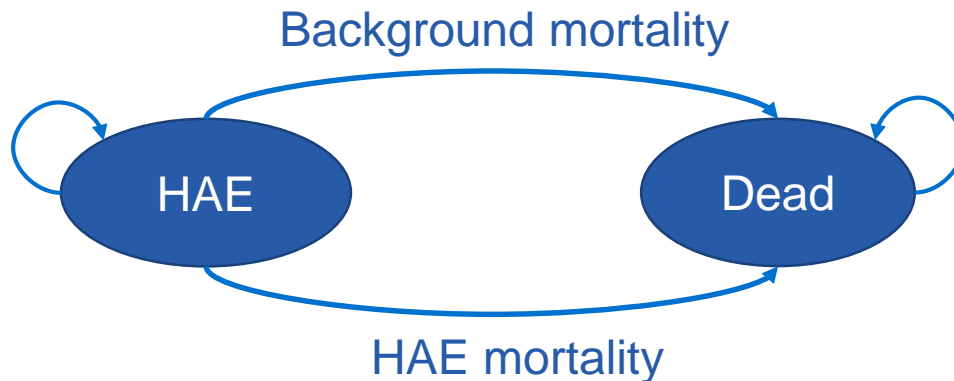

For each cycle:

- Number of attacks
- Attack-free duration
- Prophylaxis drug costs
- On-demand drug costs
- Other health care costs
- Indirect costs

# Model Structure: HAE Attack Pathway

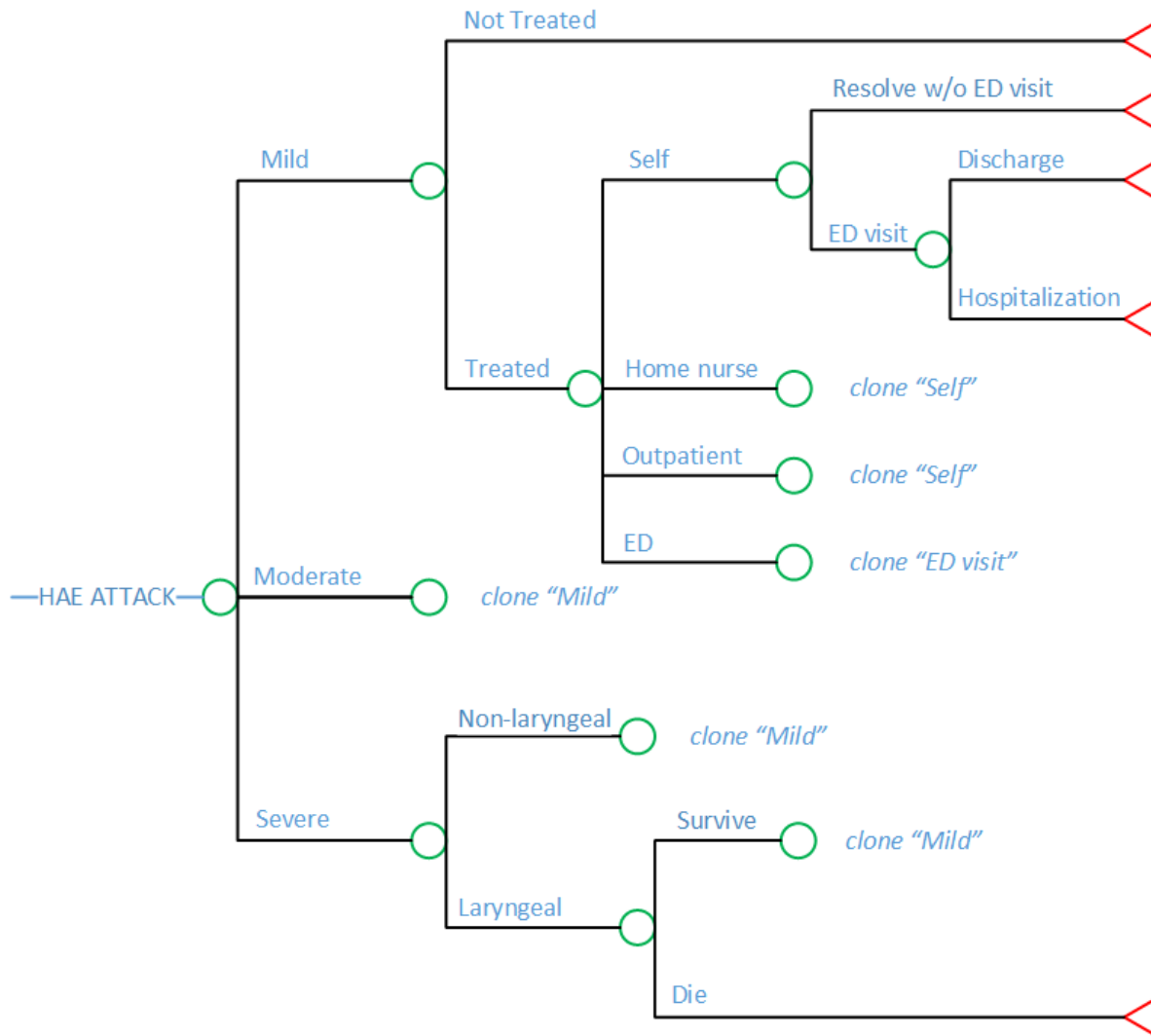

For each attack, we calculated the expected (mean):

- Direct costs
- Indirect costs
- Disutility
- Probability of death
- Duration with symptoms



---

# Inputs: Attack Characteristics

Variable	Value	Source
<b>Severity of Attack (%)</b>		
<b>Mild</b>	36.6%	Riedl et al., 2016
<b>Moderate</b>	46.2%	
<b>Severe</b>	17.2%	
<b>Proportion of Severe that are Laryngeal (%)</b>	11.5%	Riedl et al., 2016
<b>Fatality Rate from Laryngeal Attack</b>	0.0019%	Calculated from Zanichelli et al., 2015

---

# Inputs: HAE Attack Pathway Parameters

- Treatment probabilities
  - 90% of mild attacks are treated
  - 100% of moderate and severe attacks are treated
- Attack duration:
  - Treated attacks: 1 day (mild), 1 day (moderate), 2 days (severe)
  - Untreated attacks: +1 additional day
  - Fatal laryngeal attack: 4.5 hours
- Setting of administration for on-demand treatment:
  - Mild and moderate attacks: self-administration (65%), home nurse administration (14%), physician office/outpatient urgent care (21%)
  - Severe attacks treated in ED, and 40.9% of ED visits result in a further hospitalization

# Inputs: Treatment Effects

Treatment Effect Estimates on the Number of Attacks

Variable	Lanadelumab	Cinryze	Haegarda
% Mean Reduction in Attack Rate	86.9%	50.5%	84.0%

Treatment Effect Estimates on the Severity of Attacks for Haegarda

	Placebo, Number of Attacks (%)	Treated, Number of Attacks (%)	Multinomial Logit Estimates	
			Constant, estimate (standard error)	Treated, estimate (standard error)
Mild	123 (26%)	30 (42%)	-	-
Moderate	243 (52%)	34 (48%)	0.68 (0.11)	-0.56 (0.27)
Severe	106 (22%)	7 (10%)	-0.15 (0.13)	-1.31 (0.44)

# Inputs: Utilities

State	Effect	Attack Free	With Attacks
EQ-5D today (during attack-free periods)	Baseline	0.825	
	Age	-0.02205 per 10-year increase in age	
	# attacks*	-	-0.0043 per attack
EQ-5D during an attack	Mild attack	-	-0.07
	Moderate attack	-	-0.369
	Severe attack	-	-0.486

Source: Cross-sectional EQ-5D survey of Swedish HAE patients (Nordenfelt et al, 2014)

Proportion attack-free obtained from clinical trials (Banerji et al., 2017; Zuraw et al, 2010; Longhurst et al, 2017);

\* # of attacks per month (mean number in those having attacks)

# Inputs: Drug Costs and Dosing for Long-term Prophylaxis

- Prophylactic therapies are taken on a life-long basis

Intervention	Admin	Unit	FSS per dose unit*	ASP+9%†	Dosing
Lanadelumab	SC	300 mg	\$16,520	-	300 mg every 2 weeks
Haegarda‡	SC	2,000 IU	\$1,393		60 IU/kg twice a week
Haegarda‡	SC	3,000 IU	\$2,090		60 IU/kg twice a week
Cinryze	IV	500 U	\$2,012	\$3,049	1,000 U twice a week

\*FSS (Federal Supply Schedule) price

† ASP (Average Sales Price) plus 9% markup for physicians' offices, home infusion, and hospital outpatient administered units.

‡We used gender-specific weight distributions to calculate average number of 2,000 IU and 3,000 IU vials, accounting for wastage and selecting minimum cost vial combination.

---

# Inputs: Health Care Utilization Costs for Treatment of Acute HAE Attack

- Average costs per attack computed by weighting cost of available on-demand drugs by the proportion of attacks treated with each drug, for each setting of administration
- Additional cost for home nurse administration (\$177), physician office administration (\$262), ED visits (\$1,479) and hospitalization (\$4,760)

	<b>Berinert</b>	<b>Kalbitor*</b>	<b>Firazyr</b>	<b>Ruconest</b>
<b>Dose schedule</b>	20 IU/kg	30 mg	30 mg	50 IU/kg
<b>FSS price per dose</b>	\$4,174	\$11,174	\$7,178	\$10,112
<b>ASP per dose</b>	\$9,807	\$15,594	\$7,178	\$15,164
<b>% requiring extra dose</b>	2%	12%	13%	10%

\* Not approved for self or home nurse administration

# Results

---

# Monthly Prophylaxis Drug Costs

Drug	First Month	Subsequent Months
Haegarda	\$31,684	\$31,482
Cinryze, self-administered	\$33,287	\$32,561
Cinryze, physician administered	\$50,518	\$50,518
Lanadelumab	\$35,380	\$35,279



# Base Case: Discounted Lifetime Results

Drug	Prophylaxis Drug Costs	Acute Treatment Costs (Drugs & Other Services)	Total Direct Costs	Attacks	LY	QALY	ICER vs. No Prophylaxis
No long-term prophylaxis	\$0	\$10,072,000	\$10,072,000	1,703	23.55	17.47	
Cinryze	\$9,469,000	\$4,986,000	\$14,455,000	843	23.55	18.21	\$5,870,000
Haegarda	\$8,897,000	\$1,465,000	\$10,362,000	273	23.55	18.65	\$243,000
Lanadelumab	\$9,970,000	\$1,320,000	\$11,289,000	223	23.55	18.66	\$1,020,000

ICER: incremental cost-effectiveness ratio; LY: life year; QALY: quality-adjusted life year

Costs have been rounded to the nearest \$1,000.

Incremental cost-effectiveness ratios have been rounded to the nearest \$1,000, or \$10,000 when over \$1 million.

# One-Way Sensitivity Analysis - Haegarda

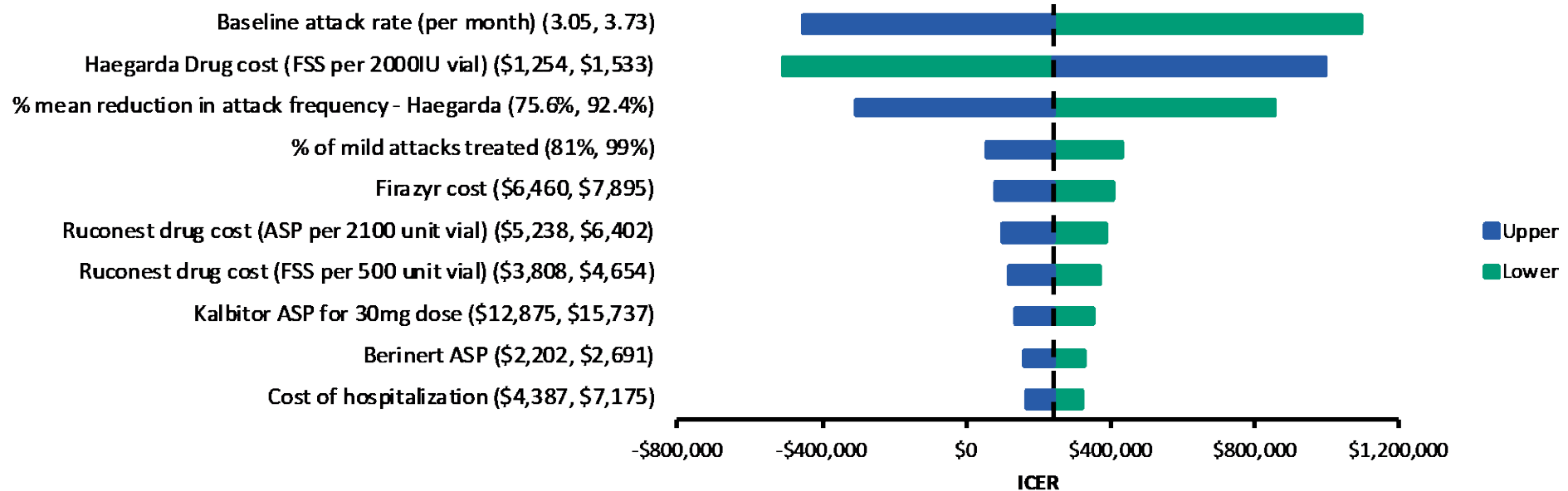

# Probabilistic Sensitivity Analysis

Cost-Effectiveness Acceptability Curve (CEAC)

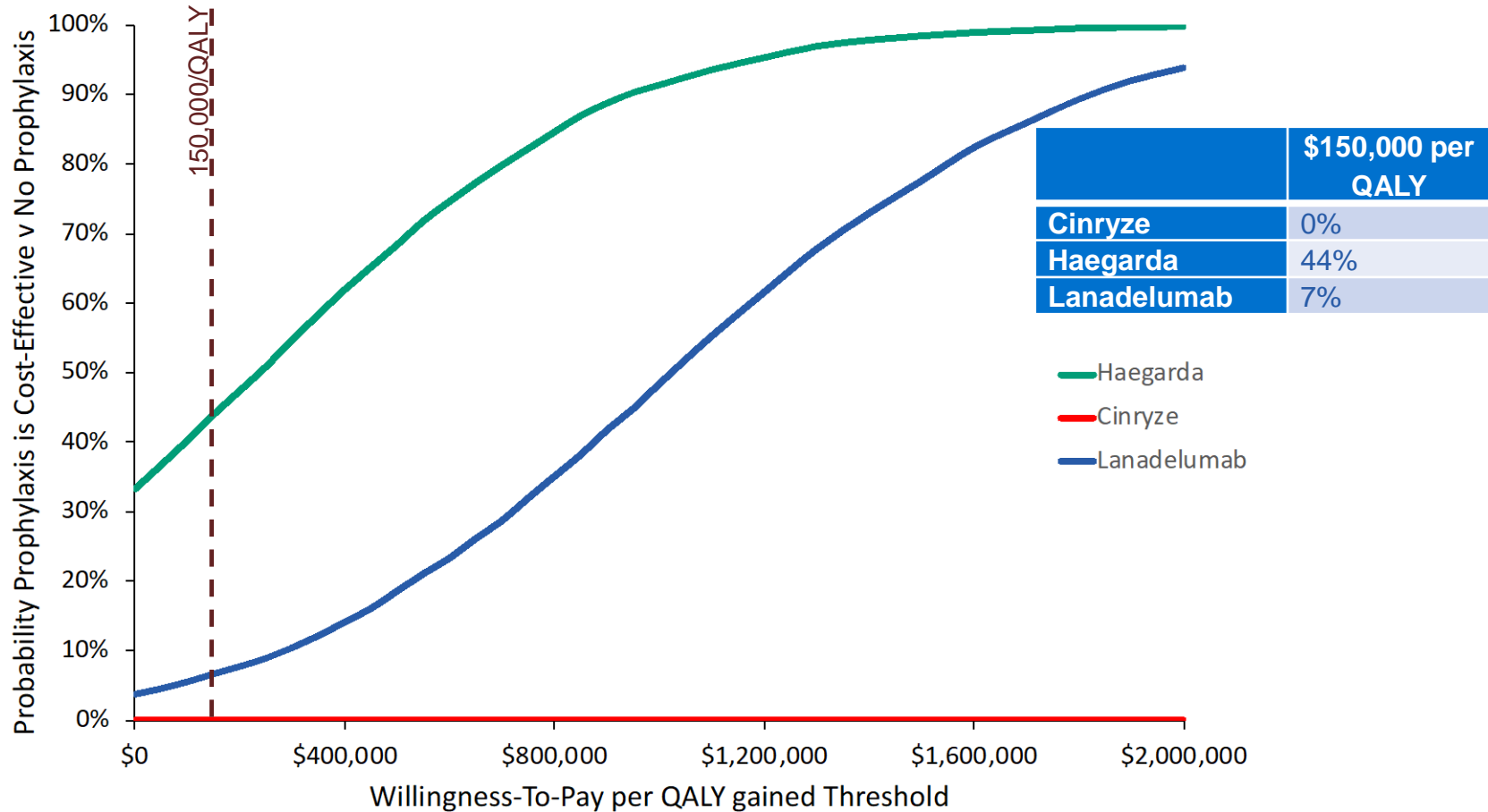

# Baseline Attack Rate to Achieve Cost-Effectiveness Thresholds

Incremental Cost-Effectiveness Ratios (Health System Perspective)  
versus Attack Rate

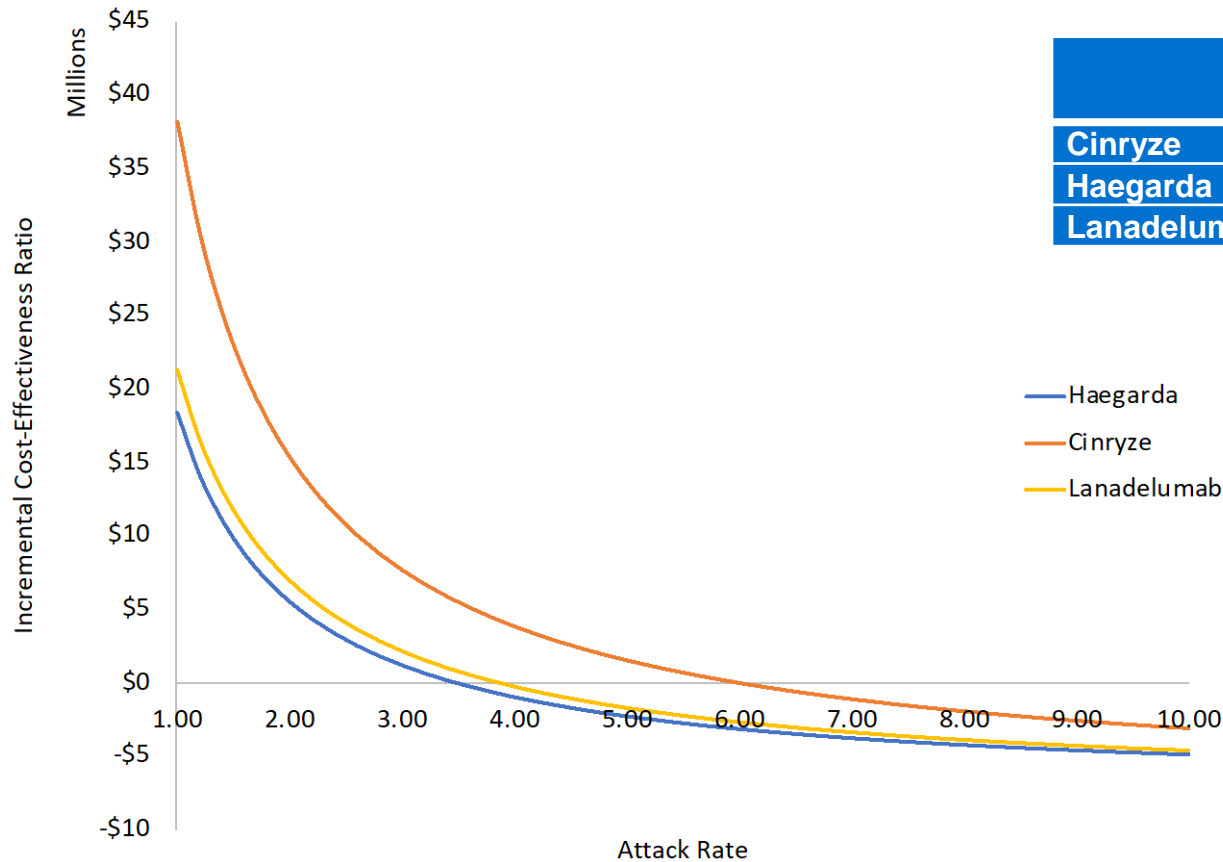

	\$150,000 per QALY
Cinryze	5.85
Haegarda	3.43
Lanadelumab	3.78

---

# Scenario Analyses

- Modified societal perspective
  - Only Haegarda's incremental cost-effectiveness ratio dropped below the \$150,000/QALY threshold
- Lanadelumab dosing: Attack-free patients on every 2 week dosing switch to every 4 week dosing at 6 months
  - If all attack-free patients switch: lanadelumab becomes dominant over no prophylaxis
  - Switching thresholds:
    - 68.2% of attack-free patients switch: <\$150,000/QALY
    - 79.9% of attack-free patients switch: Dominant

---

# Limitations

- Lack of natural history data on attack rates over patients' lifetimes
- Small sample sizes and short durations in trials
- Inadequate data on the effects of Cinryze and lanadelumab prophylaxis on severity of acute attacks
- Lack of US data on utilities and HAE-specific mortality
- Lack of real-world data on lanadelumab dosing and utilization

---

# Major Comments Received

- Proportions requiring additional doses of on-demand treatment are inaccurate
- Some proportion of patients on every 4 week dosing of lanadelumab who are attack free may be considered for every two week dosing
- For Haegarda, use weight-based dosing separately for male and females

---

# Summary

- In base-case analyses, prophylactic therapies exceed cost-effectiveness thresholds of \$150,000 per QALY
- Haegarda drops below the \$150,000 per QALY threshold when evaluated from a modified societal perspective
- Lanadelumab becomes dominant over no prophylaxis when ~80% of patients who are attack free are switched to a four week dosing regimen at 6 months
- The results were highly sensitive to baseline attack frequency, prophylactic (and on-demand) drug costs, and treatment effect estimates



# **Appendix: Cost-Effectiveness Analyses**

# One-Way Sensitivity Analysis - Cinryze

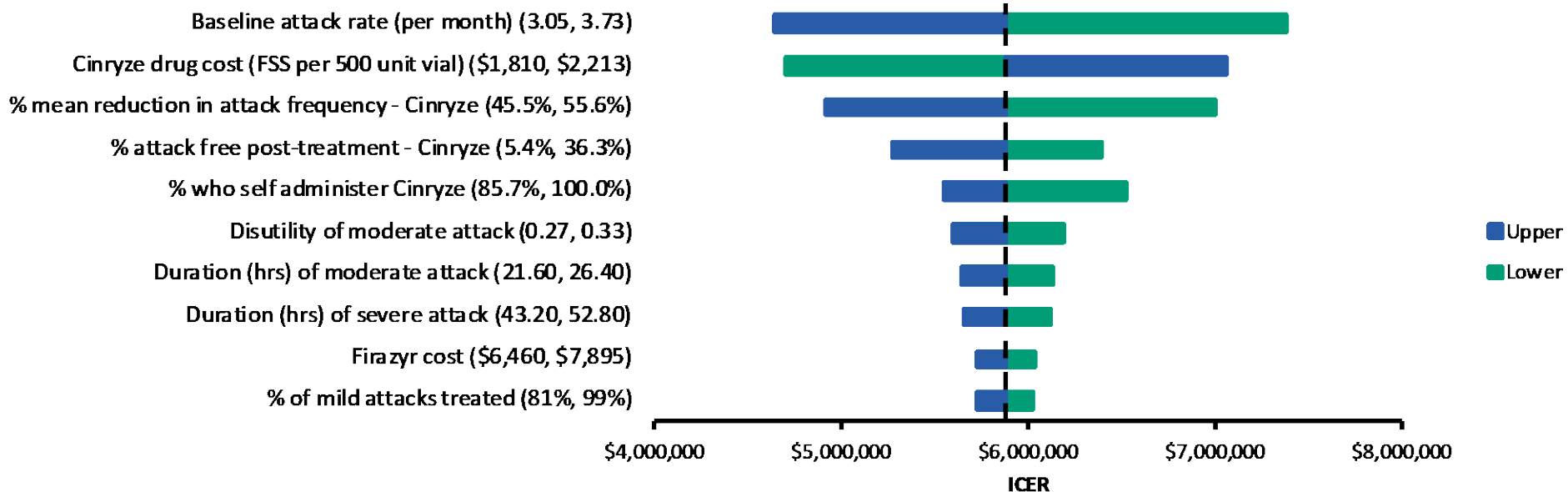

# One-Way Sensitivity Analysis - Lanadelumab

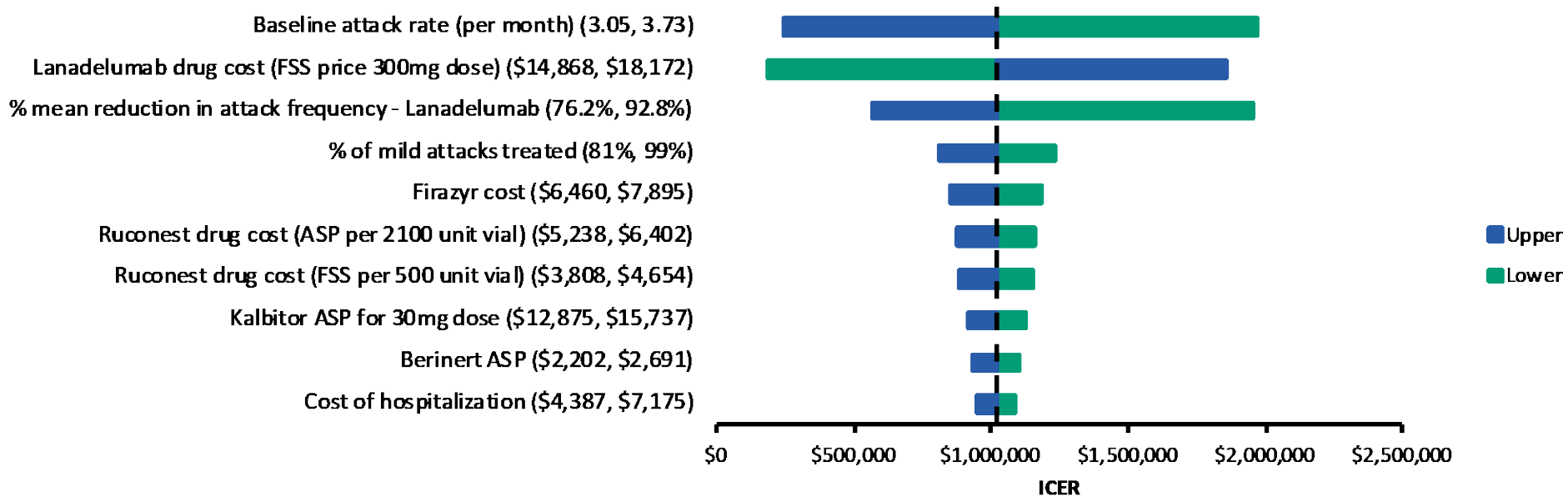

# Effects on Attack Severity

Drug	Prophylaxis Drug Costs	Acute Treatment Costs (Drugs & Other Services)	Total Direct Costs	Attacks	LY	QALY	ICER vs. No Prophylaxis
No long-term prophylaxis	\$0	\$10,072,000	\$10,072,000	1,703	23.55	17.47	
Cinryze	\$9,518,000	\$4,531,000	\$14,049,000	843	23.55	18.33	\$4,584,000
Haegarda	\$8,897,000	\$1,465,000	\$10,362,000	273	23.55	18.65	\$243,000
Lanadelumab	\$9,982,000	\$1,199,000	\$11,182,000	223	23.55	18.68	\$914,000

# Modified Societal Perspective: Discounted Lifetime Totals

Drug	Prophylaxis Drug Costs	Acute Treatment Costs (Drugs & Other Services)	Indirect Costs	Total Costs	Attacks	LY	QALY	ICER vs. No Prophylaxis
No long-term prophylaxis	\$0	\$10,072,000	\$151,000	\$10,223,000	1,703	23.55	17.47	
Cinryze	\$9,469,000	\$4,986,000	\$74,000	\$14,530,000	843	23.55	18.21	\$5,770,000
Haegarda	\$8,897,000	\$1,465,000	\$18,000	\$10,380,000	273	23.55	18.65	\$132,000
Lanadelumab	\$9,970,000	\$1,320,000	\$20,000	\$11,309,000	223	23.55	18.66	\$911,000

Indirect costs: \$959 for mild, \$4,048 for moderate, and \$6,656 for severe attacks, after adjustment for the mean number of attacks (26.9) (Wilson et al., 2010)

ICER: incremental cost-effectiveness ratio; LY: life year; QALY: quality-adjusted life year

Costs have been rounded to the nearest \$1,000.

Incremental cost-effectiveness ratios have been rounded to the nearest \$1,000, or \$10,000 when over \$1 million.

# Reduced Dosing Frequency among Attack-Free Patients on Lanadelumab

Drug	Prophylaxis Drug Costs	Acute Treatment Costs (Drugs & Other Services)	Total Direct Costs	Attacks	LY	QALY	ICER vs. No Prophylaxis
No long-term prophylaxis	\$0	\$10,072,000	\$10,072,000	1,703	23.55	17.47	
Cinryze	\$9,469,000	\$4,986,000	\$14,455,000	843	23.55	18.21	\$5,870,000
Haegarda	\$8,897,000	\$1,465,000	\$10,362,000	273	23.55	18.65	\$243,000
<b>Lanadelumab</b>	<b>\$8,447,000</b>	<b>\$1,320,000</b>	<b>\$9,767,000</b>	<b>223</b>	<b>23.55</b>	<b>18.66</b>	<b>DOMINANT</b>

DOMINANT (i.e., lower costs and higher QALYs)

The threshold proportion of patients switching to every four week dosing to achieve incremental cost-effectiveness thresholds of \$150,000, \$100,000, \$50,000 per QALY, and for lanadelumab to become dominant, were 68.2%, 72.1%, 76.0% and 79.9%, respectively.

**Questions**

# Public Comment and Discussion



---

# Nancy E. Newell

Patient with Hereditary Angioedema

*Conflict of Interest:*

- None declared.

# **Manufacturer Public Comment and Discussion**

---

# Debra Bensen-Kennedy, MD

Vice President, Medical Affairs, CSL Behring

*Conflict of Interest:*

- Full-time employee of CSL Behring.

**Lunch**

**Meeting will resume at 12:20 pm**

# Voting Questions

WIFI: TCEGUEST

---

## 0. Which ice cream flavor was invented in Oakland, CA?

- A. Cookies and cream
- B. Rocky road
- C. Stracciatella
- D. Mint chocolate chip



---

***Patient Population for all questions:*** Patients with Type 1 and Type 2 Hereditary Angioedema (HAE 1/2) who are eligible for long-term prophylactic therapy.

---

1) Is the evidence adequate to distinguish the net health benefits between the C1 inhibitors Cinryze and Haegarda for long-term prophylactic therapy for HAE 1/2?

- A. Yes
- B. No





---

2) Is the evidence adequate to demonstrate that the net health benefits of long-term prophylaxis with C1 inhibitors for HAE 1/2 are superior to on-demand therapy only?

- A. Yes
- B. No



---

**3) Is the evidence adequate to demonstrate that the net health benefits of long-term prophylaxis with lanadelumab for HAE 1/2 are superior to on-demand therapy only?**

- A. Yes
- B. No



---

## 4) Does treating HAE 1/2 patients with long-term prophylactic therapy offer one or more of the following potential “other benefits” versus on-demand treatment? (select all that apply)

- A. Haegarda offers reduced complexity that will significantly improve patient outcomes.
- B. Lanadelumab offers reduced complexity that will significantly improve patient outcomes.
- C. Will reduce important health disparities across racial, ethnic, gender, socioeconomic, or regional categories.
- D. Will significantly reduce caregiver or broader family burden.
- E. Lanadelumab offers a novel mechanism of action or approach that will allow successful treatment of many patients for whom other available treatments have failed.
- F. Will have a significant impact on improving patients'/caregivers' ability to return to work or school and/or their overall productivity.
- G. Will have a significant positive impact outside the family, including on schools and/or communities.
- H. Will have a significant impact on the entire “infrastructure” of care, including effects on screening for affected patients, on the sensitization of clinicians, and on the dissemination of understanding about the condition, that may revolutionize how patients are cared for in many ways that extend beyond the treatment itself.
- I. There are other important benefits or disadvantages that should have an important role in judgments of the value of this intervention:  
\_\_\_\_\_.



## 5) Are any of the following contextual considerations important in assessing the long-term value for money of long-term prophylactic therapy for HAE 1/2? (select all that apply)

- A. Intended for the care of individuals with a condition of particularly high severity in terms of impact on length of life and/or quality of life.
- B. Intended for the care of individuals with a condition that represents a particularly high lifetime burden of illness.
- C. First to offer any improvement for patients with this condition.
- D. Compared to on-demand treatment only, there is significant uncertainty about the long-term risk of serious side effects of using C1 inhibitors.
- E. Compared to on-demand treatment only, there is significant uncertainty about the long-term risk of serious side effects of using lanadelumab.
- F. Compared to on-demand treatment only, there is significant uncertainty about the magnitude or durability of the long-term benefits of using C1 inhibitors.
- G. Compared to on-demand treatment only, there is significant uncertainty about the magnitude or durability of the long-term benefits of using lanadelumab.
- H. There are additional contextual considerations that should have an important role in judgments of the value of this intervention:  
\_\_\_\_\_.

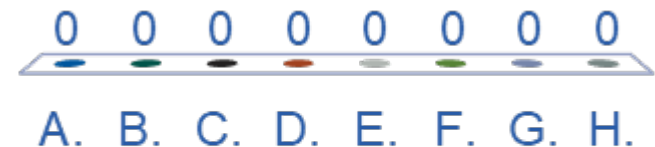

---

6) Given the available evidence on comparative effectiveness and incremental cost-effectiveness, and considering other benefits, disadvantages, and contextual considerations, what is the long-term value for money of long-term prophylaxis of HAE with Cinryze versus on-demand therapy?

- A. Low
- B. Intermediate
- C. High

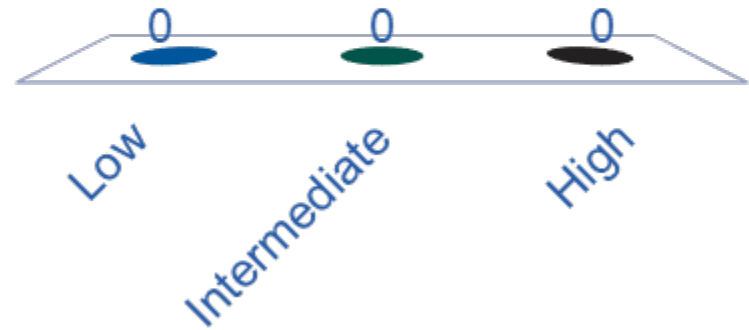

---

7) Given the available evidence on comparative effectiveness and incremental cost-effectiveness, and considering other benefits, disadvantages, and contextual considerations, what is the long-term value for money of long-term prophylaxis of HAE with Haegarda versus on-demand therapy?

- A. Low
- B. Intermediate
- C. High

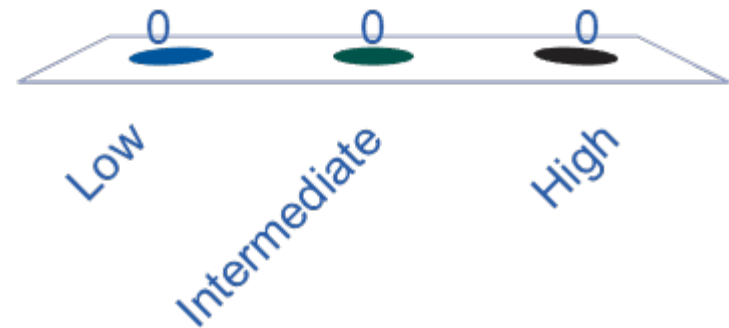

---

8) Given the available evidence on comparative effectiveness and incremental cost-effectiveness, and considering other benefits, disadvantages, and contextual considerations, what is the long-term value for money of long-term prophylaxis of HAE with lanadelumab versus on-demand therapy?

- A. Low
- B. Intermediate
- C. High

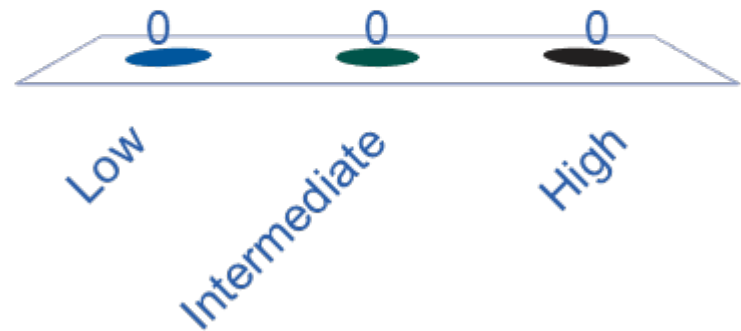

**Break**

**Meeting will resume at 1:35 pm**



# Policy Roundtable

---

# Policy Roundtable Participants

Name	Title	COI Declaration
<b>Debra Bensen-Kennedy, MD</b>	Vice President, Medical Affairs, CSL Behring	Full-time employee of CSL Behring.
<b>Marco Cicardi, MD</b>	Professor of Medicine, Università degli Studi di Milano, Italy	Received consultancy fees from Shire and CSL Behring; speaker for Shire, CSL Behring, and Pharming; received research and educational support from Shire and Pharming; principal investigator in lanadelumab, Ruconest, and Haegarda clinical trials.
<b>April Kunze, PharmD</b>	Senior Director, Formulary Development and Trend Management Strategy, Prime Therapeutics	Full-time employee of Prime Therapeutics.
<b>Stephanie Smith</b>	Patient Advocate	Receives honoraria for work as a patient advocate for Haegarda and CSL Behring.

# CTAF Panel Reflections

---

## Next Steps

- Meeting recording posted to ICER website next week
- Final Report published on/about November 15
  - Includes description of CTAF votes, deliberation; policy roundtable discussion
- Materials available at <https://icer-review.org/topic/hereditary-angioedema/>

**Adjourn**